

Physics 23 Fall 2003
Lab 2 - The Photoelectric Effect

Theory

In 1887 Heinrich Hertz discovered that when electromagnetic radiation of sufficiently high frequency shines on a clean metal surface, electrons are emitted from the surface. This phenomena is called the photoelectric effect. The photoelectric effect can be studied with an apparatus similar to the one shown in figure 1. It consists of an evacuated glass tube in which two metal electrodes

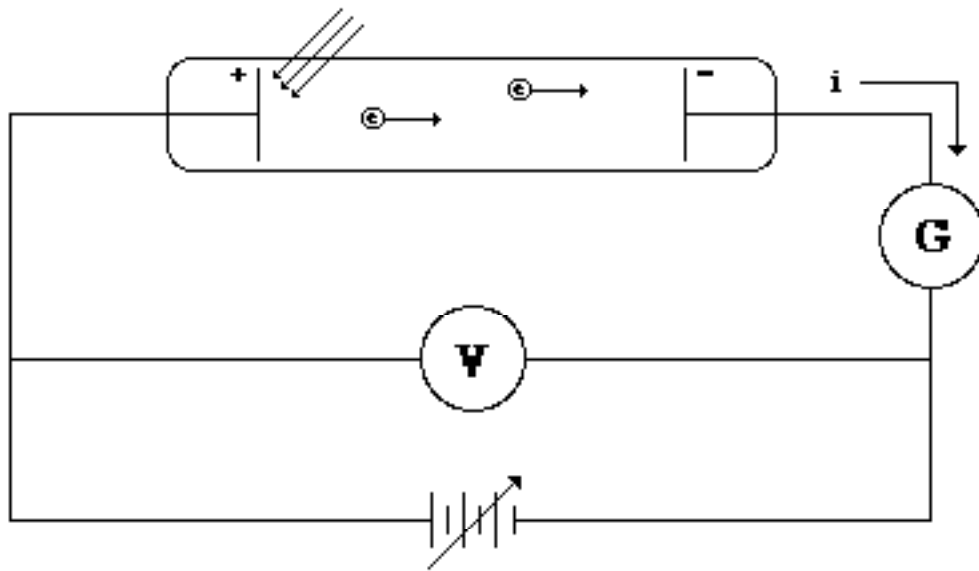

Figure 1

are embedded, a variable power supply to create a potential difference V between the electrodes, a voltmeter to measure V , and a galvanometer to measure the photocurrent i .

When monochromatic light falls on the anode, electrons are emitted in the direction of the cathode with various kinetic energies. In passing from the anode to the cathode, work (numerically equal to eV) is done on the electrons by the retarding voltage thereby causing them to lose energy. The retarding potential that will just stop all of the photoelectrons is called the stopping potential V_o . Given the stopping potential, the speed of the most energetic electrons can be determined from the expression

$$eV_o = \frac{1}{2} m_o v_{\max}^2 = E_{\max} \quad . \quad (1)$$

At the turn of the century when Hertz and others were doing their experiments on the photoelectric effect, the dominant theory of the nature of light was the wave theory. In this theory, light was postulated to consist of oscillating electric and magnetic fields which propagated in continuous waves. The energy in the wave was contained in the oscillating electric and magnetic

fields and was thought to be spread uniformly over the entire wave. The energy content of the wave was characterized by its intensity, the amount of energy which flows per unit time through a unit area perpendicular to the wave direction.

The wave theory had been very successful up to that point in explaining phenomena involving light, but when it was applied to the photoelectric effect it could not explain all of the major experimental results. For example, according to the wave theory, the ejection of an electron from the surface of a metal occurred because of the interaction between the electric field of the light wave and the electric charge of the electrons. The oscillating electric field acting on the charged electrons would set them into vibration with an amplitude proportional to the square root of the energy they absorbed from the field. When an electron had absorbed enough energy, it would be literally vibrated out of the metal. If the light beam had a high intensity, this would happen quickly; but if the light beam had a low intensity, it would take some time before the electron had accumulated enough energy to be ejected from the metal. For a low intensity light beam, there would be an appreciable time lag between when the beam first struck the metal and when the first electron was ejected. Experiment showed no such time lag.

A second area of difficulty concerned the relationship between the energies of the ejected electrons and the intensity of the light. The average kinetic energy of any vibrating body is proportional to the square of its amplitude of vibration. According to the wave theory, the square of the amplitude of vibration is proportional to the square of the amplitude of the oscillating electric field which, in turn, is proportional to the intensity of the light. In other words,

$$(\text{avg. kin. eng.}) \propto (\text{amp. of vib.})^2 \propto (\text{amp. of elec. fld.})^2 \propto (\text{intensity}) .$$

Thus, the kinetic energies of the ejected electrons should show some dependence on the intensity of the light. Experiment showed the kinetic energies of the ejected electrons to be independent of the intensity.

In 1905 Albert Einstein explained the photoelectric effect using quantum ideas introduced a few years earlier by Planck in his theory of blackbody radiation. According to Einstein, the energy in a light beam was not spread out uniformly over a continuous wave, but rather was concentrated in bundles, quanta of energy (called photons), each having an energy $h\nu$ where ν is the frequency of the electromagnetic wave. A light beam then could be thought of as a beam of photons with the intensity being a measure of the photon density. It is a collision between a single photon and single electron which, provided the photon contains enough energy, results in an ejected electron. Upon collision the electron completely absorbs the energy of the photon. If this energy is greater than the energy ϕ needed to overcome the attractive force at the surface, then some electrons will be ejected from the metal. Energy conservation requires that the most energetic electrons have an energy E_{max} ,

$$E_{\max} = h\nu - \phi \quad (2)$$

where ϕ (called the work function) is a constant which depends on the composition of the emitting surface.

With Einstein's theory we can easily overcome the difficulties encountered by the wave theory. Since an electron absorbs all the energy a photon has in its collision with the photon, there is no time delay between the exposure of the surface to light and the ejection of the first electrons. There is no slow accumulation of energy. Furthermore, since the intensity of the light is a measure of the photon density and not their energy, there should be no relationship between the intensity of the beam and the kinetic energy of the ejected electrons. Either the photon has enough energy to eject the electron or it doesn't. If it does not, then no electrons will be emitted no matter how intense the beam.

In this laboratory, you will use an apparatus similar to the one described at the beginning of this writeup to reproduce some of the major experimental features of the photoelectric effect, and with those data, test some predictions based on Einstein's theory. In particular, we will obtain a value for a fundamental universal constant which characteristically appears in quantum phenomena, Planck's constant h .

References

- 1) Beiser, 2.3 and 2.4
- 2) Serway (Kresge reserve), 2.5

Experimental Purpose

From Einstein's theory of the photoelectric effect the following predictions can be made:

1. According to equation (2), the maximum kinetic energy of the photoelectrons is given by

$$E_{\max} = h\nu - \phi \quad .$$

Equation (1) tells us that the maximum kinetic energy is also given by

$$E_{\max} = eV_0 \quad .$$

Substituting this into equation (2) yields

$$eV_0 = h\nu - \phi \quad . \quad (3)$$

If we let $eV_0 = y$, $n = x$, $h = a$ and $\phi = b$, then equation (3) is a linear equation of the form $y = ax + b$. Therefore, a plot of eV_0 vs ϕ should yield a straight line with a slope equal to Planck's constant and a y-intercept equal to the work function.

2. According to the equation (2), for a given frequency the maximum kinetic energy is a well defined constant and is independent of the intensity of the light. According to equation (1), if E_{\max} is constant and independent of the intensity, then V_0 is also constant and independent of the intensity. Therefore, for a given frequency a plot of the photocurrent i vs V should yield the same value of V_0 for any intensity of light.

The purpose of this lab is to test these predictions. From other methods of measurement, the accepted value for Planck's constant is 6.625×10^{-34} J-sec and the accepted value for the work function for the cathode material we use is 2.85×10^{-19} joules.

Procedure

The apparatus for this experiment (shown in figure 2 at the top of the next page) consists of a mercury lamp, a set of Kodak Wratten filters, an RCA phototube, a beaker of water, a Keithley microvoltmeter, a 30 V dc power supply, a helipot ten-turn potentiometer, and an x-y recorder. The mercury lamp emits light with well defined frequencies in the visible region of the spectrum.

[CAUTION: the mercury lamp also gives off radiation in the ultraviolet region which is harmful to the eyes. Do NOT stare at the mercury lamp when it is in operation]. This light passes through the water-filled beaker which focuses the light onto the emitting surface in a commercial RCA 929 phototube. Certain emitted frequencies can be isolated (hence, making the light monochromatic) by placing an appropriate filter between the mercury lamp and the phototube. The filters are number coded and isolate the following frequencies:

<u>color</u>	<u>filter number</u>	<u>frequency isolated</u>
violet	49-B	6.88×10^{14} Hz
green	74	5.49×10^{14} Hz
orange	22	5.19×10^{14} Hz
red	29	4.34×10^{14} Hz

[Note: There is a diffraction grating included with the filters which can be used to view the four lines that will be isolated by the filters. To use it, hold the grating in front of the mercury tube and look to one side of the grating. If you do not see the line emission spectrum, then rotate the grating by 90° and try again.] The phototube is mounted in a light-tight box with a window in order to reduce the effects of stray light. Its construction is similar to the evacuated glass tube shown in figure 1. The retarding voltage is supplied by the 30 V dc power supply and can be varied from positive values through zero to negative values with the use of the helipot potentiometer. The

retarding voltage is fed to the x-scale of the x-y recorder, so that as the retarding voltage is swept from negative values through zero to positive values the pen of the x-y recorder will sweep horizontally from left to right. The photocurrent from the phototube is measured with the Keithley

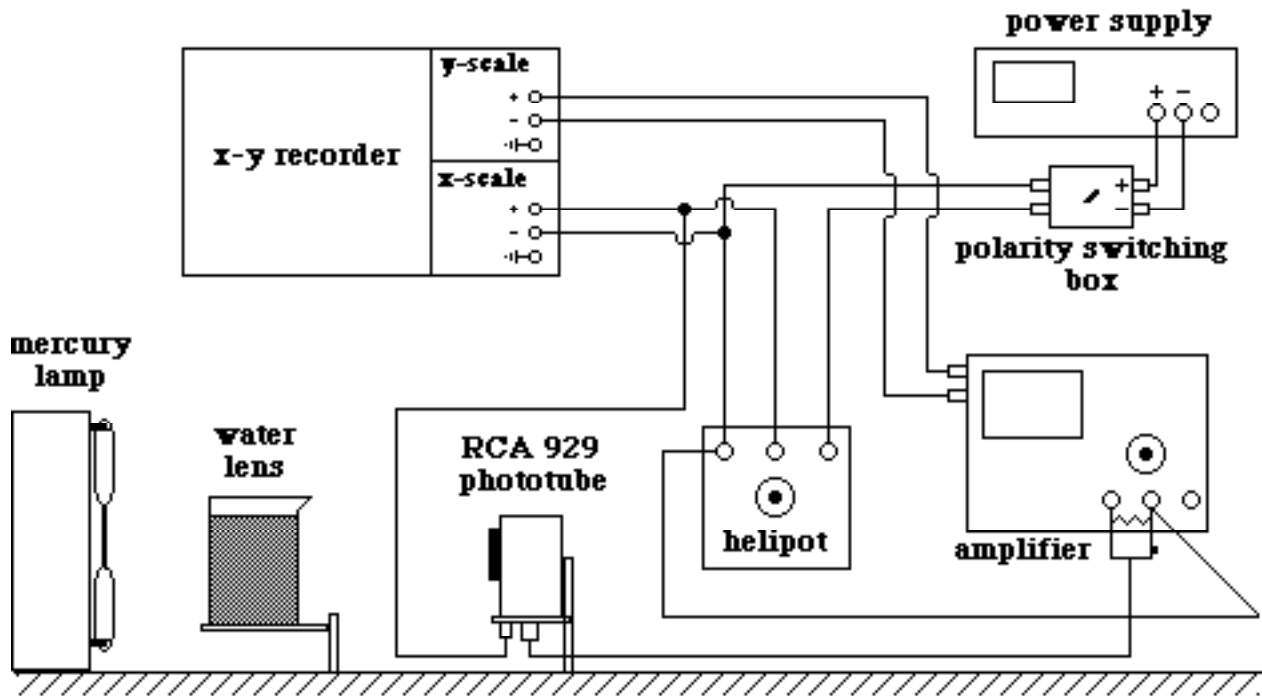

Figure 2

microvoltmeter. A voltage proportional to the photocurrent is fed from the Keithley to the y-scale of the x-y recorder. Hence, the x-y recorder plots the photocurrent vs voltage, i vs V .

Note: The settings for the electrical equipment given in the following procedures are nominal values. It may be necessary to vary them somewhat depending on the characteristics of your specific phototube and electronic equipment.

Part A

The purpose of part A is to allow you to observe the large scale characteristics of the photocurrent vs retarding voltage curve. The procedure is as follows.

1. Insert a blank piece of paper into the x-y recorder. Make sure that a strip of black tape shadows the "anode" in the phototube in order to minimize dark current. Place the opaque slide into the slot in the front of the phototube.

Turn on all of the apparatus. The x-y recorder has four switches. The LINE switch should be in the "On" position, the SERVO switch should be in the "Off" position, the CHART switch should be in the "Hold" position, and the PEN switch should be in the "Up" position. [Note: Some of the recorders have only three switches. The LINE switch and the SERVO switch are combined into one switch labeled POWER/SERVO. If you are using one of these recorders the POWER/SERVO switch should be in the "On-Off" position.] Set the power supply to 5

volts. Set the RANGE control on the Keithley meter to 3 mV full scale. Set the Keithley ON-OFF control to the ZERO CHK position and check to see that the meter's needle indicates a zero reading. If it does not, then zero the Keithley using the ZERO control. When the Keithley is zeroed, set its ON-OFF control to the "On" position. Set the x-scale of the x-y recorder to 1V/in and the y-scale to the setting between 100 mV/in and 1V/in. Make sure the polarity switch on the polarity box is set to - .

Adjust the beaker-mercury-lamp-phototube system so that the phototube is positioned about 30 cm from the mercury lamp with the water filled beaker as close to the mercury tube as possible. [**Caution:** water and electrical equipment can be a lethal mixture. If the water lens gets knocked over at any time during the lab when the electrical equipment is turned on, get away from the lab station immediately. Do NOT touch any of the electrical equipment. Notify any nearby students and your TA about the spill.] Make sure the light leaving the water lens is focused onto the phototube. If it is not, move either the spectrum tube power supply or the water lens until it is. Turn the helipot dial full counter-clockwise, so that it supplies zero voltage. Turn the SERVO switch on the x-y recorder to the "On" position (or the POWER/SERVO switch to the "On-On" position). Using the x-zero and y-zero controls on the recorder, position the pen at the bottom middle of the paper for $V = 0$. Then turn the helipot dial full clockwise so that it supplies maximum negative voltage. The pen should be on the far left side of the recorder.

2. Turn off the lights in the room. Remove the cap from the pen and put it in some secure location. Turn the PEN switch on the recorder to the "Down" position to record the dark-current curve. SLOWLY turn the helipot dial counter-clockwise until it is full counter-clockwise. Mark that position which is the zero of the retarding voltage scale. Reverse the polarity of the leads to the electrodes in the phototube by flipping the switch on the polarity box to + . Turn the helipot dial clockwise until it is full clockwise. This trace is the "zero line" for your current-voltage curve. Set the PEN switch on the recorder to the "Up" position and return the pen to the lefthand side of the paper.
3. Turn the SERVO switch on the recorder to the "Off" position. Replace the opaque slide by the violet filter (#49-B). [**Caution:** Do not let the unfiltered light shine on the phototube for long periods of time]. Turn the SERVO switch to the "On" position. Sweep the pen across the recorder, as you did with the opaque slide, to the far right side of the recorder. Using the y vernier control adjust the y gain until the pen is near the top of the recorder. Return the pen to the far left side of the recorder. Put the pen down and slowly sweep the pen across the paper. When you get to the far right hand side of the paper, set the PEN switch to "Up" and return the pen to the left hand side of the paper.
4. On the same sheet of paper, repeat step 3 with the phototube 50 cm from the mercury lamp. By moving the phototube further from the light source, what are we changing?

5. On the same sheet of paper, repeat step 3 with the phototube 70 cm from the mercury lamp.

You will find that the current does not go exactly to zero at large retarding voltages, but instead saturates at a small negative value. This dark current is due to photoemission from the anode. It is very much smaller than the saturation forward current because the anode has a much smaller surface area and, in this experiment, because the anode is shadowed. (It would be smaller still if the anode had a higher work function than the cathode, but the manufacturer does not take such pains with this tube since it is intended for use with a forward bias).

Part B

The purpose of part B is to measure the stopping potential V_0 for four frequencies of light. We are essentially doing the same thing as in part A except that we are using a more sensitive scale and we are looking only at retarding voltages in the negative voltage region. The procedure is:

1. Set the polarity on the polarity box to - . Insert a new sheet of paper into the x-y recorder. Set the SERVO switch to "Off", the CHART switch to "Hold" and the PEN switch to "Up". Adjust the beaker-mercury lamp-phototube system so that the phototube is positioned about 55 cm from the mercury lamp with the beaker midway between. Set the Keithley meter to 100 microvolts full scale. Leave all other settings the same. The violet filter should still be in the slot in the front of the phototube. Turn the SERVO switch to "On-On". Turn the helipot dial full clockwise. Using the x-zero and y-zero controls on the recorder, position the pen near the bottom lefthand corner of the paper. Set the PEN switch to "Down" and SLOWLY sweep the pen from left to right by turning the helipot dial counter-clockwise. When the pen gets near the top of the paper, set the PEN switch to "Up" and the SERVO switch to "Off". Replace the violet filter with the opaque slide. Finish turning the helipot until it is full counter-clockwise. Put the SERVO switch to "On" and the PEN switch to "Down". Using the y-zero control on the recorder, mark the zero retarding voltage position. Label your trace with the filter used and x-scale setting.
2. Repeat step 1 using the green filter (#74).
3. Repeat step 1 using the orange filter (#22).
4. Repeat step 1 using the red filter (#29). For this step, move the phototube to a position 30 cm from the mercury lamp.
5. Compute the stopping potential for each frequency. [Note: Some setups may show a linear bias in the photocurrent vs retarding voltage plots as shown in figure 3a at the top of the next page. This bias shows up most frequently in part B where the you are working on more sensitive settings on the Keithley amplifier. If your setup shows this linear bias, draw a straight

line through the linear portion of the plot to the vertical line representing the zero retarding voltage and then measure the distance along that line from where the photocurrent curve leaves the line to the zero retarding voltage line (see figure 3b). Use this distance to compute the stopping potential.]

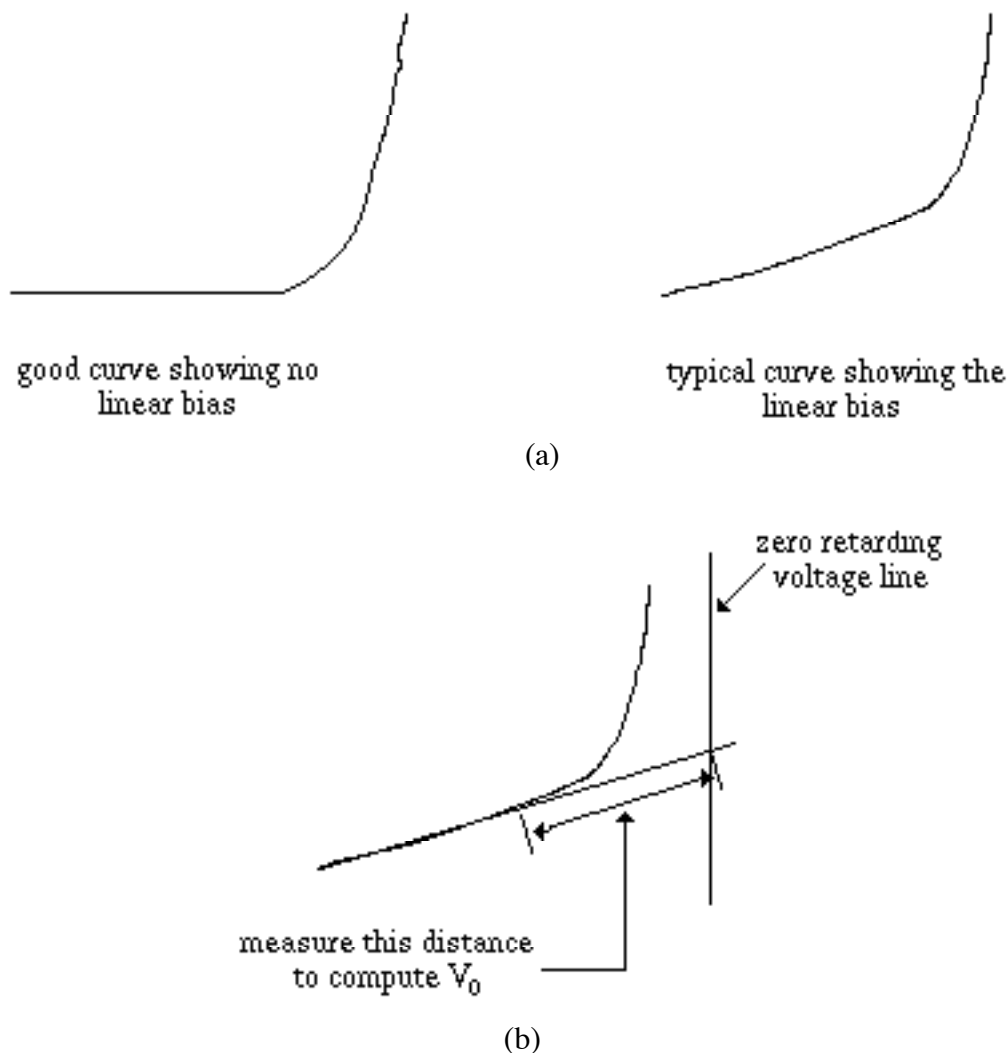

Figure 3

Plot eV_0 vs λ and compute the slope of the line. Compare the measured slope with the accepted value. From your graph determine an experimental value for the work function ϕ .

When you have completed step 4 turn off all of the equipment, put the cap on the pen and discard any plots that you don't want.

Lab Report

Follow the usual lab notebook format. Your lab report should include the answers to all of the questions asked in the introduction or procedure, all raw and derived data, and an estimate of the magnitude and sources of error in any data recorded. When answering any question or when giving

any comparison or explanation, always refer to specific data to support your statements.

For this lab, also include the following:

1. the i vs V plot made in part A with an explanation of why it has the shape it does; point out as many features of the photoelectric effect as you can that the plot illustrates;
2. the i vs V plots made in part B with an explanation of how you computed V_o from them;
3. a table containing the experimental (V_o, λ) data points;
4. a graph of eV_o vs λ with an explanation of why it has the shape it does;
5. a computation of the slope of the eV_o vs λ graph with a comparison to the accepted value;
6. a determination of the work function ϕ from the graph; express it in electron-volts.; (What is the smallest frequency to which the 929 can respond? Show how you arrived at that value.); and
7. a discussion of the sources of error in this lab with an estimation of their magnitude.