

**SECTION 23 05 00****COMMON WORK RESULTS FOR HVAC****PART 1 - DESIGN DIRECTIVES****1.1 SUMMARY**

- A. The Dartmouth Design & Construction Guidelines include general administrative, design, product, and installation requirements. It is the intent of Dartmouth College that the consultant incorporates the requirements contained herein with the consultant's specifications to produce a document that is cohesive, coordinated, and non-conflicting. Deviations from these Guidelines must be reviewed and approved by the appropriate DC-FO&M Engineering representative.

**1.2 CODE CONFORMANCE**

- A. All systems shall be designed and installed in conformance with applicable State of New Hampshire and Town of Hanover codes outlined in Section 01 00 00, as well as any other specific codes or standards referenced in the various Division 23 sections.
- B. Applicable codes and standards include, but are not limited to:
1. All applicable federal, state, and local codes and standards, including the International Building Codes, NFPA, National Electric Code, OSHA, etc., as adopted and amended by the State of New Hampshire and Town of Hanover, New Hampshire.
  2. State of New Hampshire, "State Fire Code", adopted edition, including all applicable references.
  3. Town of Hanover, Ordinance #15
  4. Hanover Department of Public Works miscellaneous standards
  5. ANSI/ASME Power Piping Code B31.1

**1.3 ENVIRONMENTAL DESIGN CRITERIA**

- A. Consultants shall use ASHRAE weather data for Lebanon, NH for mechanical equipment sizing.
1. Heating Design Conditions:
    - a. Mean - Extreme Annual Temperature shall be used for sizing heating equipment:
      - 1) -17.1<sup>0</sup> F
  2. Cooling Design Conditions:
    - a. 0.4% Occurrence - Annual Cooling, Dehumidification, and Enthalpy Design Conditions, shall be used for sizing cooling equipment:
      - 1) Cooling: 88.8<sup>0</sup>F DB, 70.9<sup>0</sup>F MCWB
      - 2) Dehumidification: 71.6<sup>0</sup> DP, 119.5 HR, 78.8 MCDB
- B. Energy use calculations shall be performed using TMY3 weather data from Lebanon Municipal Airport.
- C. Indoor spaces shall be designed for the following setpoints during occupied hours:

D.

Heating	69.0° F
Cooling	75.0° F

1. Systems shall be capable of providing setbacks/ setups during unoccupied hours.
2. Spaces with occupancy sensors shall be capable of providing standby setbacks.
3. Thermostats with setpoint adjustment capability shall only be capable of relaxing setpoints to conserve energy (e.g., make cooler in winter and warmer in summer). Adjusted setpoints shall not be greater than 69.0° F for heating, or less than 75.0° F for cooling.

**1.4 HOT WATER SYSTEMS**

- A. Heating systems for all new buildings and major renovations shall be hydronic. Elimination of steam heating systems and replacement with hydronic systems shall be evaluated for minor renovations. New hydronic systems shall be designed to be compatible with existing (if available) or future campus district hot water heating network.
- B. Building hot water heating and domestic hot water heating systems shall be isolated from the campus district hot water network by plate and frame heat exchangers selected for low approach (2 degrees F or less).
- C. Building Hot Water Requirements:
  1. Buildings and systems shall be designed to meet heating requirements using the following schedule of building-side hot water temperatures:

	Maximum HW Supply Temp.	Maximum HW Return Temp.
New construction and existing building hot water conversions	120° F	100° F

2. Designers working in existing buildings that have significant existing hot water infrastructure shall work with FO&M Engineering to agree on hot water systems design approach and reasonable target design temperatures.
- D. Domestic Hot Water Requirements:
  1. Buildings that produce domestic hot water (DHW) using campus district hot water shall design DHW heating system to produce 140° F domestic hot water using supplemental heating systems such as solar thermal, heat pumps, or electric heaters.

**1.5 CHILLED WATER SYSTEMS**

- A. Cooling systems shall be designed using the following district chilled water parameters:

	Chilled Water Supply Temp	Building Chilled Water Return Temp
Summer	45°F	60°F - 65°F (optimum) 57°F minimum
Winter	50°F	

- B. Designers should consider the possibility of brief (1 to 2 hour) interruptions of service, where the chilled water supply temperature could rise to as high as 60°F. Back-up chillers should be installed in any building with critical applications where brief loss of temperature or humidity control would not be acceptable.
- C. The campus district chilled water systems have a two-stage variable primary pumping arrangement where the district chilled water plant pumps the 1st stage of pumping for meeting building pressure requirements. In the event that pressure available from the district is insufficient to meet a building's differential pressure (dP) setpoint, secondary pumps (2nd stage) at each building will be enabled to maintain pressure as needed.
- D. The diagram below illustrates the campus standard chilled water entrance. Please note that the diagram is schematic in nature and does not show all valves, strainers, gauges, etc. that are necessary for a complete design.

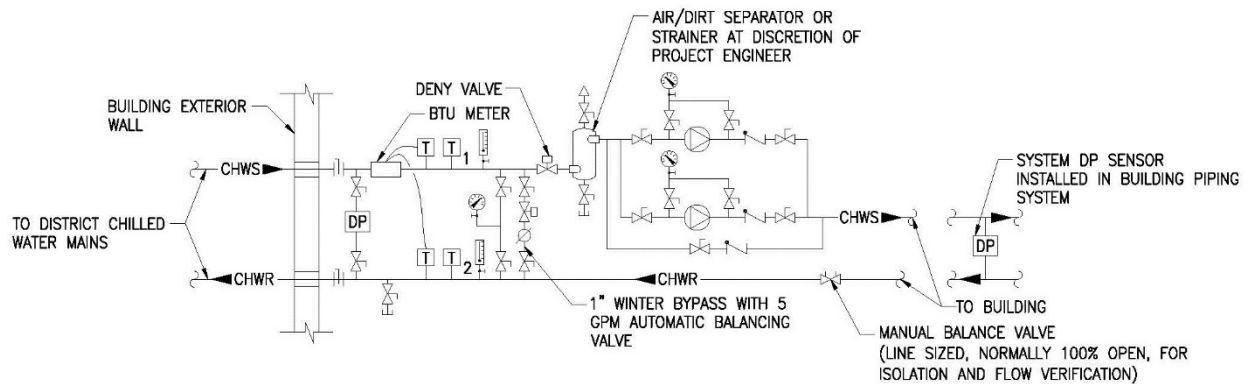

- E. The building chilled water pumps and deny valve shall be controlled by a pressure differential sensor in the building. The design engineer shall select appropriate location for the dP sensor in building. The building dP setpoint may reset based on building valve positions if determined appropriate by design engineer.
- The following sequence of operation shall be used to control the chilled water entrance deny valve and pumps:
  - Whenever cooling is disabled, the deny valve shall be 100% closed and the chilled water pumps shall be off. When cooling is enabled, the deny valve shall open to its minimum position setpoint = 10% (adj). Based on the deviation of the measured building differential pressure (dP) and the dP setpoint, a PID control loop shall calculate a dP demand output that varies 0% to 100%. As the dP demand increases from 5% to 40% (adj.), the deny valve shall modulate from minimum position to 100% open. As the dP demand varies from 45% to 100% the building pump(s) shall start and shall modulate from the minimum speed = 25% (adj.) to 100%. As the dP demand output decreases, the reverse sequence shall occur.
  - The chilled water energy meter shall be an ultrasonic or magnetic meter as specified in DC Design Guideline, "23 05 19 - Meters and Gauges for HVAC Equipment". The meter shall calculate chilled water energy use by using water flow, supply and return  $\Delta T$ . The energy usage shall be calculated in ton-hours and shall be communicated to the building control system along with flow and temperature data.

## 1.6 DOMESTIC HOT WATER SYSTEMS

- A. Domestic hot water systems shall be capable of producing (and storing if appropriate) 140°F water. Approved tempering valve(s) capable of reducing the DHW supply temperature to 110°F shall be installed in the distribution system in accordance with IPC (NH adopted edition). Although use of the district heating system for hot water heating is preferred, domestic hot water generating

heat pumps, solar hot water heating systems, and electric hot water heaters are acceptable alternatives to using district hot water for some applications – to be reviewed and approved by FO&M Engineering.

- B. The designer shall carefully examine the requirements of water tempering valves where there are recirculation pumps – specifically, minimum flows through the mixing valve and the flow rate required to insure proper mixing.
- C. Domestic hot water recirculation systems shall be installed per International Plumbing Code (NH adopted edition) and designed per ASPE (American Society of Plumbing Engineers) recommended procedures.
  - 1. Systems shall be designed to insure that hot water reaches fixtures in 15 seconds or less.
  - 2. Distribution systems shall minimize dead legs.
  - 3. Domestic hot water recirculation pumps, where required, shall be variable-speed with ECM motors. Pump speed shall be controlled by the BMS, where available, to maintain return water temperature at 105°F (adj.). Pumps shall be capable of being scheduled off during unoccupied hours. Where the BMS is not available, provide local controls.
- D. Point of use water heaters should be considered when estimated hot water storage capacity is less than 6 gallons.

### 1.7 WATER TREATMENT SYSTEMS

- A. All heating and cooling water systems shall be chemically treated to prevent accumulation of scale and corrosion. Designers and building contractors shall consult and coordinate with FOM Engineering and FO&M's water treatment vendor to understand project requirements to comply with current water treatment program.

Closed loop heating systems shall include a side water treatment loop. Water shall be drawn off of the bottom of an air/dirt separator and pumped through a filter feeder and coupon rack, returning to the building hot water supply line. A site glass makes balancing the loop to a desired flow possible using an isolation valve. See diagrams below illustrating sample system configurations. Please note that the diagrams are schematic in nature and do not show all valves, strainers, gauges, etc. that are necessary for a complete design.

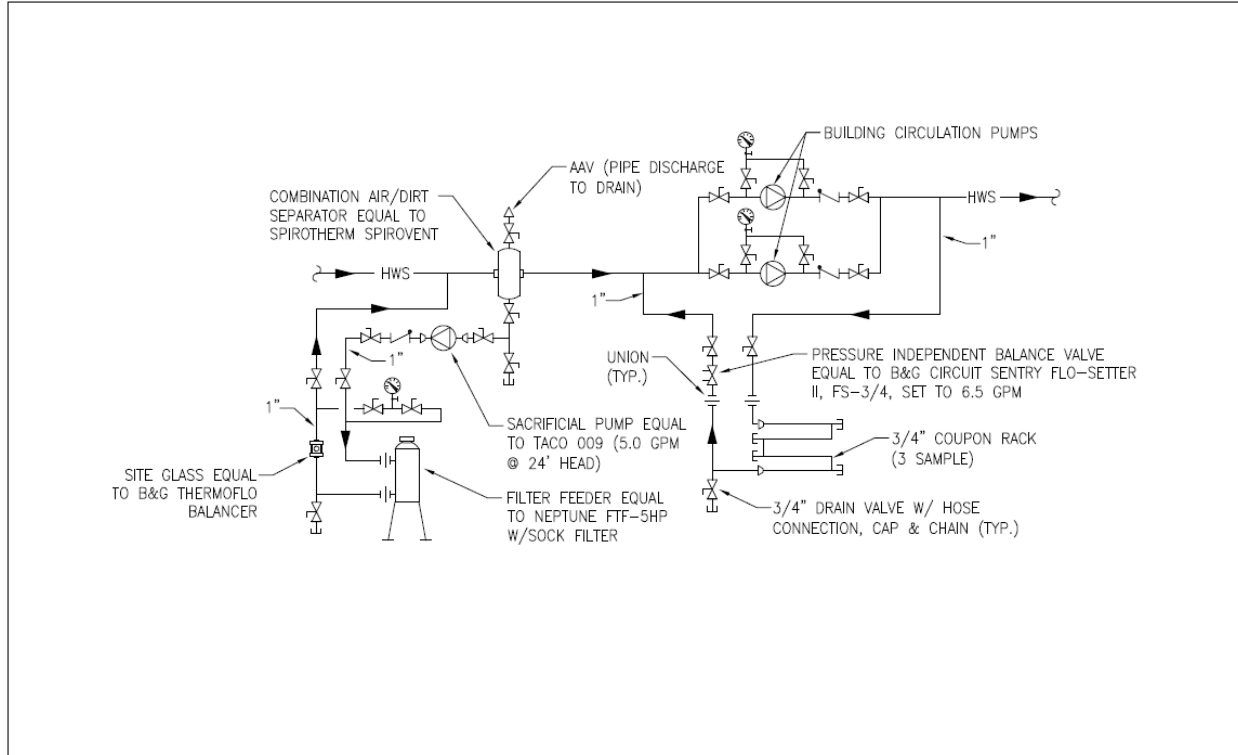

**1.8 STEAM SYSTEMS**

- A. All Steam systems shall be designed to withstand 30 psig, or 1.5 times normal operating pressure (whichever is greater). This includes, but not limited to, steam traps, coils, valves, and PRV's. Minimum steam pressure for design purposes shall be 15 psig.

**1.9 ELECTRIC ROOMS**

- A. All electric transformer vaults and major electric rooms shall be ventilated. Intake air for these spaces shall be filtered.

**1.10 MECHANICAL ROOMS**

- A. Show coil and filter pulls on drawings.
- B. Provide floor drains near equipment for condensate, backflow preventers, etc.
- C. Meters and gauges shall be accessible, visible and able to read without use of ladders.
- D. Designs shall plan for adequate space to service all equipment:
  - 1. Every effort shall be made by the designer to position and locate equipment and devices to facilitate access for inspection, maintenance, repair, and replacement.
  - 2. Accessible is defined as being visible and able to be reached, tested, rewired, removed, etc. from the ground or from a legal stepladder height without requiring the removal of any building component or MEP equipment or parts. Maintenance personnel shall not be required to climb into a space above a ceiling &/or crawl or lay on ductwork or mechanical equipment to reach the item to be serviced.

3. Apparatus such as air-handlers, pumps, and controls shall not be suspended over stairs, auditorium seating or other uneven planes unless a permanent means for accessing is installed.
4. Equipment shall be installed at such a height that the serviceable parts are accessible from a standard stepladder that can be raised & opened in the space under the ceiling. Equipment weighing over 300 lbs. may require overhead eyebolt for chain fall or rail for crane attachment.

### 1.11 KITCHEN EXHAUST HOODS

- A. Dartmouth College FO&M has reviewed the requirements of NFPA 96 with the Hanover Fire & Building Departments for proper application in Dartmouth College facilities. Each application needs to be reviewed with the Town during design to determine the appropriate system. As a basis of the discussion, the following system types have been developed:
  1. System One: Installations conforming to the requirements of NFPA 96. Recommended applications are commercial kitchens creating grease laden vapors.
  2. System Two: Installations with deep stainless steel hoods with lock seams or welded seams (Vent A Hood model SLH18-142SS) and one integral fan. Both sides the hood shall extend 6" further than the range. Ductwork shall be galvanized steel conforming to the requirements of this Guideline. A potassium carbonate based fire suppression system shall be installed (refer to DC Standard 15300) and, if the building is so equipped, connected to the fire alarm system (separate zone, if available). The fire suppression system shall deactivate the fuel (electric or propane) to the appliances under the hood. Recommended applications shall be dormitory buildings and residence halls, including Community Director's apartments in new construction & major renovations involving the kitchen; business uses for occasional use by the building occupants and the reheating of foods by caterers.
  3. System Three: Installations using residential style, hoods with self-contained fans (Broan #4000; Nutone #SM6530WW). Hood width shall be the same as the range. Ductwork shall be galvanized steel conforming to the requirements of this Guideline. Recommended applications shall be single family residences.

### 1.12 REFRIGERATION SYSTEMS

- A. Dartmouth College has elected to abide by the requirements of chapter 11, 'Refrigeration' of the International Mechanical Code and ASHRAE Standard 15, 'Safety Code for Mechanical Refrigeration'. Where the requirements of the documents differ, the more stringent of the two shall be followed. Where refrigerant sensors are required, provide the device specified herein. A visible device shall be located on the exterior of each entrance to the mechanical room housing the refrigerant device. A single point shall notify the Central Heating Plant, via the DDC control system, of any alarm or mechanical failure of the refrigerant monitoring system. Dartmouth College is currently writing a Standard Operating Procedure for actions to be taken when the sensor is in alarm. The consultant shall obtain this document to ascertain signage requirements.
- B. Refrigerant monitoring systems shall be refrigerant specific. Sensors shall be non-calibrating type. The sensor module shall continuously self calibrate. The remote alarm shall be a visual (strobe light) only. Provide a refrigerant test kit for the project. Manufacturer shall be Thermal Gas Systems, model Haloguard or Haloguard II.

### 1.13 PIPE ROUTING

- A. Wherever possible, water and waste piping shall not be located in high value rooms (i.e., computer server rooms). If piping is located over electric power equipment, install drain pan or enclose piping.

**1.14 3D PRINTERS**

- A. 3D printers shall be contained on at least five sides and maintained at slight negative pressure relative to room while printer is in operation. Exhaust taken from printers shall be prohibited from being recirculated to building.

**1.15 EQUIPMENT AND MACHINERY**

- A. Equipment and appurtenances shall be designed in conformity with ANSI, ASME, IEEE, NEMA, OSHA, AGMA and other generally accepted applicable standards.
- B. All machinery and equipment shall be safeguarded in accordance with the safety codes of the ANSI, OSHA, and local industrial codes, including but not limited to, shaft guards on all rotating shafts, cages around exposed fan blades, etc.
- C. All mechanical work shall be performed by mechanics who are qualified to do such work and who are normally engaged in this type of work.

**1.16 ACOUSTICS**

- A. All mechanical systems shall conform to ANSI standards, with maximum permissible background noise of 40 dba in all spaces. The following NC levels shall be the basis for maximum total equipment noise 5 ft from the unit or air discharge/return location permitted in the areas noted in table below.

<b>NOISE LEVEL</b>	
<b>SPACE TYPE</b>	<b>NC</b>
Public Areas (corridors, entries)	35-40
Lounges	35-40
Private Offices	30-35
Conference Rooms	30-35
Classrooms and Auditoriums	30-35
Dormitory Bedrooms	30-35
Laboratories	40-45

- B. Acoustic design requirements similar to those stated in ASHRAE Handbook – HVAC Applications, Chapter 47, Tabel 42, Design Guidelines for HVAC-Related Background Sound in Rooms shall also be used as a reference.

**PART 2 - PRODUCTS**

**2.1 PRODUCT MANUFACTURERS**

- A. Dartmouth College encourages the use of domestic fabricated products; however, we realize that not all products are made in North America or are shipped from manufacturers from both domestic and foreign plants. Non-domestic products are acceptable except when explicitly required to be domestic.

**PART 3 - EXECUTION****3.1 DESIGN PROCESS, DRAWINGS, AND DELIVERABLES**

- A. Designers shall provide a narrative to be included on the drawings or in the specifications that describes the intent and design parameters of each mechanical system in the project.
- B. All drawings shall be prepared in electronic format compatible with AutoCad, and GIS format for underground utility work. References to alternate bids, changes due to value engineering, or other reasons shall be incorporated into a “conformed” set of Construction drawings and specifications indicating the final design actually installed. Sketches issued during construction shall be made by modifying the original documents. This will provide a solid base from which the contractor can prepare the as-built drawings.
- C. Refer to Refer to DC Guidelines, “010000 - General Requirements” section for ‘Close Out Procedures’ and record drawing requirements.
- D. Development of design documents is an evolutionary process. In order to provide appropriate feedback to consultants in a timely manner, Dartmouth College expects to see, as a minimum, the following information at the stated design stage:



<b>Design Document Information Matrix</b>	
Conceptual Design	<ul style="list-style-type: none"> <li>• Basis of Design and proposed systems narrative.</li> <li>• Preliminary heat loss/gain calculations.</li> <li>• Estimated loads of utilities &amp; proposed connection points.</li> <li>• Applicable codes, including zoning, building, fire, mechanical, electrical, plumbing, &amp; energy.</li> <li>• Required environmental conditions for each space defined:                             <ul style="list-style-type: none"> <li>○ Wet &amp; dry bulb, occupied &amp; unoccupied;</li> <li>○ Ventilation and indoor air quality requirements;</li> <li>○ Special conditions (humidity levels, noise / vibration sensitive areas, redundant life safety or security areas, etc.);</li> <li>○ User acceptable ranges of above.</li> </ul> </li> </ul>
Schematic Design	<ul style="list-style-type: none"> <li>• Drawing convention established, floor plans drawn indicating primary mechanical routes and shaft sizes &amp; locations, standard details, legend, mechanical rooms identified, space requirements indicated, basis of design narrative describing equipment operation and intended sequences of operation, and emergency power requirements.</li> <li>• Seismic requirements shall be determined &amp; submitted to owner.</li> <li>• Infrastructure support data compiled and evaluated (water pressure &amp; flow, steam and condensate requirements, etc.).</li> <li>• System types and major equipment selections shall be proposed, including energy saving schemes.</li> <li>• Any diversity factors used in design analysis or selections.</li> <li>• Fuel &amp; electrical use estimates.</li> <li>• Acoustical requirements.</li> <li>• Initial construction &amp; operating costs estimates.</li> <li>• Energy saving scheme developed with lifecycle cost calculations.</li> </ul>
Design Development	<ul style="list-style-type: none"> <li>• Floor plans furthered developed, some distribution into individual areas shown (include sizing), mechanical rooms 50% complete, flow schematics 75% complete, major equipment schedules shown, and ATC sequence of operations 50% complete.</li> <li>• Specifications 75% complete and in conformance with DC Design &amp; Construction Guidelines.</li> <li>• Energy savings schemes limited to two or three systems with associated life cycle cost analysis for review with DC.</li> <li>• Impact on infrastructure fully analyzed addressed.</li> </ul>
50% Const. Drawings	<ul style="list-style-type: none"> <li>• Floor plans show more detail into individual areas, mechanical spaces 75% complete, flow schematics substantially complete, all equipment schedules shown and ATC point schedule &amp; sequence of operations 75% complete, some cross sections &amp;/or elevations.</li> <li>• Specifications 90% complete.</li> </ul>
90% Const. Drawings	<ul style="list-style-type: none"> <li>• Drawings substantially complete: flow schematics &amp; ATC point schedule and sequences of operations 100% complete, mechanical spaces, equipment schedules, cross sections/elevations, details 99% complete.</li> <li>• Specifications 100% complete.</li> </ul>

Dartmouth College will review & comment on the documents at each phase.

E. CAD drafting standards shall incorporate as a minimum the following:

1. Text is not written over room names or over walls.
2. Call-outs (leader lines) shall be used wherever possible, shall not be at the same angle as the architecture, and shall not cross each other.
3. Locate schedules, details, sections, etc. from the right side of the page to the left.

4. Linework shall be appropriately broken and dashed, when necessary, to clearly illustrate pipe and ductwork intersections.
  5. All pipe and ductwork shall be labeled with flow arrows.
  6. Drops and risers shall be tagged with what the riser is, the size, and “up to\_\_” or “dn to\_\_”.
  7. Clear indication of existing versus new and points of interconnection.
- F. The designer shall include flow schematics for all hydronic systems, steam & condensate systems, and air systems. Plumbing riser diagrams shall be provided for sanitary waste and vent and domestic water systems.
- G. Equipment schedules shall include the following:
1. Electrical requirements including voltage, phase, minimum circuit ampacity, maximum fuse size, starter requirements, and brake horsepower ratings for all motors.
  2. Minimum energy efficiency ratings.
  3. Sound data for air handling equipment (by octave band for large air handlers).
  4. Thermal Capacity requirements.
  5. A listing of standard features and required options.
- H. All designs shall consider energy savings measures. The consultant shall prepare estimated energy consumption data for review by Dartmouth College.
- I. All consultants shall thoroughly review the site conditions and all available prints prior to designing modifications or additions to existing structures.

### 3.2 CONSTRUCTION COORDINATION

- A. The mechanical contractor is responsible for coordinating the work of his trade with all other trades prior to the commencement of construction. Recognizing that the construction drawings are generally schematic in nature, Contractors’ original bids shall include provision of all necessary offsets, fittings, transformations, etc., as required to provide a complete project. Any conflicts must be brought to the attention of the architect/engineer/owner. Any work requiring removal and reinstallation due to the lack of coordination shall be the responsibility of the contractors with no additional cost to the owner.
- B. Where specified by the design consultant, or where deemed necessary by the contractors or owner, prepare coordination drawings to a scale of 3/8"=1'-0" or larger; detailing major elements, components, and systems of mechanical equipment and materials in relationship with other systems, installations, and building components.
1. Indicate the proposed locations of piping, ductwork, equipment, and materials. Include the following:
    - a. Clearances for servicing and maintaining equipment, including tube removal, filter removal, and space for equipment disassembly required for periodic maintenance.
    - b. Equipment connections and support details.
    - c. Clearance to access all electronic equipment such as VAV controllers.
    - d. Fire-rated wall and floor penetrations.
    - e. Sizes and location of required concrete pads and bases.
    - f. Valve stem movement.
    - g. Seismic bracing locations.
  2. During coordination meetings discuss amongst the contractors scheduling, sequencing, movement, and positioning of large equipment into the building during construction.
  3. Prepare reflected ceiling plans to coordinate and integrate installations, air outlets and inlets, light fixtures, communication systems components, sprinklers, and other

ceiling-mounted items. Maintain minimum required clearances between air outlets and smoke detectors.

- C. Pipe appurtenances requiring service are not allowed in electric rooms.

### 3.3 INSPECTION

- A. Prior to performing work required under Division 23 the contractor shall carefully inspect all existing conditions and the installed work of all other trades and verify that all conditions and all such work is complete to the point where the mechanical work may properly commence.
- B. In the event of discrepancy, immediately notify Architect/Engineer/owner.

### 3.4 QUALITY ASSURANCE

- A. Ample clearance shall be provided for repairs, inspection and adjustment. Protruding members such as joints, corners and gear covers shall be finished in appearance. All exposed welds shall be ground smooth and the corners of structural shapes shall be rounded or chamfered.
- B. Secure and pay for all necessary fees, permits and approvals, as required for the work of this Section.

#### C. CUTTING AND PATCHING

1. Perform cutting, fitting, and patching of mechanical equipment and materials required to:
  2. Uncover Work to provide for installation of ill-timed Work.
  3. Remove and replace defective Work.
  4. Remove and replace Work not conforming to requirements of the Contract Documents.
  5. Remove samples of installed Work as specified for testing.
  6. Install equipment and materials in existing structures.
- D. Protect the structure, furnishings, finishes, and adjacent materials not indicated or scheduled to be removed.
  - E. Provide and maintain temporary partitions or dust barriers adequate to prevent the spread of dust and dirt to adjacent areas.
  - F. Patch finished surfaces and building components to match existing using new materials specified for the original installation and experienced Installers.

### 3.5 PERFORMANCE AND COMMISSIONING

- A. Projects that are pursuing LEED Certification or that have an MEP scope of work exceeding \$1M shall be commissioned by an independent Commissioning Agent.
- B. Refer to DC Guidelines, "019100 - Commissioning" for complete commissioning requirements.
- C. If the project is to be commissioned, the contractor is required to work with the commissioning agent and related sub-contractors as required to fulfill the requirements of section 019100. The costs associated with this requirement shall be included in the contractor's base bid.
- D. Perform all work that is essential in completing the intended installation in the proper manner.
- E. Field verification of all dimensions is required.
- F. Wherever obstructions are encountered in the path or course of the work that are not shown nor anticipated in the Contract Documents, do not proceed with the installation of the work before advising the Architect/engineer/owner and receiving detailed information or drawings or both.

**3.6 INSTALLATION OF EQUIPMENT**

- A. All equipment shall be installed true, level and in the location shown on the Drawings. Precision gauges and levels shall be used in setting all equipment.
- B. Furnish, install and protect all necessary guides, bearing plates, anchor and attachment bolts, and all other appurtenances required for the installation of equipment.
- C. All equipment shall be installed in such a manner as to provide access for routine maintenance, including lubrication.
- D. Structural steel supports and miscellaneous steel required for supporting and/or hanging equipment and piping furnished under this Division, shall be provided and installed.
- E. All foundations, anchor pads, piers, thrust block, inertia blocks and structural steel supports shall be built to template and reinforced as required for loads imposed on them. Provide for pipe expansion and install expansion joints that meet ASTM standards. Provide seismic bracing per IBC and NFPA.

**3.7 MECHANICAL ROOM SAFETY ISSUES**

- A. The FO&M project representative shall determine the normal walking paths within mechanical spaces. Projections of any objects in this walking space that are less than 6'-8" above finished floor that create a safety hazard shall have rounded edges and be equipped with a protective covering. The protective may be 3/4" thick elastomeric insulation or other similar product approved by FO&M. Designers shall coordinate floor drains location to minimize drain piping install on top of floors.

**3.8 CLEANING**

- A. Protect equipment against mortar, dust, weather, etc., during construction and leave all equipment clean. Remove from the premises, all debris and unused material and leave premises in a clean and neat condition.

**3.9 CLEANING, FLUSHING, AND FILLING HYDRONIC SYSTEMS**

- A. The mechanical contractor shall flush, clean, and final fill systems installed or modified with products purchased from the Campus water treatment contractor. Final fill shall not occur until the water treatment contractor has confirmed that the water is suitable for permanent chemical treatment. All strainers shall be cleaned during flush and clean period.
- B. Contractor to ensure the proper system flushing shall be performed with start-up strainers and remove after flushing has been completed at all equipment. All strainers to be checked and cleaned before the system is turned over to Dartmouth College.

END OF SECTION 23 05 00